

IG(180)DL - 8 x 3 - 6

LEGACY DESIGNATION IG-180-DL-R

DESIGNATION EXAMPLE

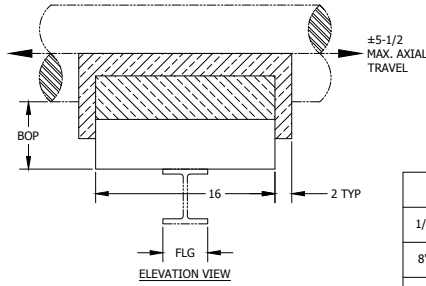
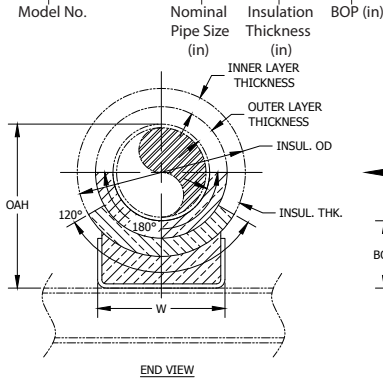

NPS	FLG (MIN)
1/2" - 6"	3"
8" - 24"	6"
26" - 72"	8"

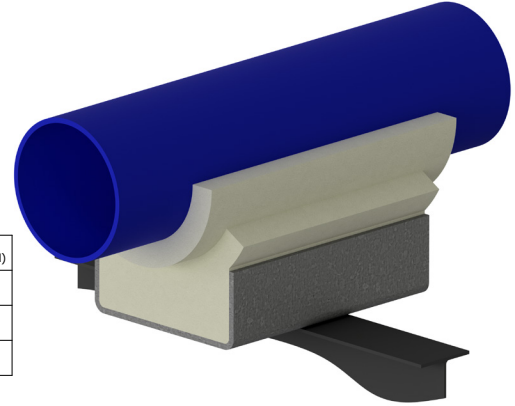

NOTES:

1) All dimensions in inches unless noted.

PIPE SIZE	INSULATION THICKNESS																				
	1"				1-1/2"				2"				2-1/2"				3"				
	BOP (in)	VERTICAL LOAD (lbs)	OAH (in)	W (in)	BOP (in)	VERTICAL LOAD (lbs)	OAH (in)	W (in)	BOP (in)	VERTICAL LOAD (lbs)	OAH (in)	W (in)	BOP (in)	VERTICAL LOAD (lbs)	OAH (in)	W (in)	BOP (in)	VERTICAL LOAD (lbs)	OAH (in)	W (in)	
Do you need special loads or dimensions for this design? Please contact us at (713) 466-4777 or sales@rilco.com!																					
1/2"	4	244	4.875	2	4	336	4.875	2.75	4	418	4.875	3.375	4	551	4.875	4.125	6	633	6.875	4.875	
3/4"	4	243	5	2.125	4	335	5	2.875	4	417	5	3.625	4	551	5	4.25	6	633	7	5	
1"	4	297	5.375	2.375	4	379	5.375	3	4	468	5.375	3.75	4	553	5.375	4.5	6	635	7.375	5.125	
1-1/4"	4	312	5.625	2.625	4	413	5.625	3.25	4	547	5.625	4	4	612	5.625	4.75	6	674	7.625	5.375	
1-1/2"	4	336	5.875	2.75	4	418	5.875	3.5	4	551	5.875	4.125	4	633	5.875	4.875	6	715	7.875	5.625	
2"	4	375	6.375	3.125	4	463	6.375	3.75	4	549	6.375	4.5	4	631	6.375	5.25	6	713	8.375	5.875	
3"	4	464	7.5	3.875	4	580	7.5	4.625	4	662	7.5	5.25	4	744	7.5	6	6	826	9.5	6.75	
4"	4	549	8.5	4.625	4	631	8.5	5.25	4	713	8.5	6	4	795	8.5	6.75	6	889	10.5	7.375	
6"	4	677	10.63	6.125	4	801	10.63	6.75	4	941	10.63	7.5	4	965	10.625	8.25	6	1048	12.625	8.875	
8"	4	1304	12.63	7.5	4	1498	12.63	8.25	4	1572	12.63	8.875	6	1727	14.625	9.625	6	1850	14.625	10.375	
10"	4	2401	14.75	9	4	2618	14.75	9.75	4	2804	14.75	10.375	6	2991	16.75	11.125	6	3178	16.75	11.875	
12"	4	4162	16.75	10.375	4	4487	16.75	11.125	4	4767	16.75	11.875	6	5047	18.75	12.5	6	5327	18.75	13.25	
14"	4	4512	18	11.375	4	4792	18	12	4	5072	18	12.75	6	5352	20	13.375	6	5632	20	14.125	
16"	4	5453	20	12.75	4	5568	20	13.375	6	5755	22	14.125	6	5853	22	14.875	6	6192	22	15.5	
18"	4	9387	22	14.125	4	9853	22	14.875	6	10320	24	15.5	6	10787	24	16.25	6	11253	24	17	
20"	4	10320	24	15.5	4	10787	24	16.25	6	11253	26	17	6	11720	26	17.625	6	12187	26	18.375	
24"	4	16249	28	18.375	4	16871	28	19.125	6	17494	30	19.75	6	18116	30	20.5	6	18738	30	21.25	
30"	4	31807	34	22.625	6	32938	36	23.375	6	34069	36	24	6	35201	36	24.75	6	36332	36	25.5	
36"	4	34069	40	26.875	6	35201	42	27.625	6	36332	42	28.25	6	37464	42	29	6	38595	42	29.75	
42"	4	36332	46	31.125	6	37464	48	31.875	6	38595	48	32.5	6	39726	48	33.25	6	40858	48	34	
48"	4	38595	52	35.375	6	39726	54	36	6	40858	54	36.75	6	41989	54	37.5	6	43121	54	38.125	
52"	4	40858	56	38.125	6	41989	58	38.875	6	43121	58	39.625	6	44252	58	40.25	6	45383	58	41	
60"	4	43121	64	43.875	6	44252	66	44.5	6	45383	66	45.25	6	46515	66	46	6	47646	66	46.625	

Applications & Features:

- Temperature range from -425 Deg F to 275 Deg F
- Higher temperature applications available
- Design loads based on a safety factor of 5
- A36 steel construction
- See technical specification RCS-750
- Test results available upon request
- Steel finish available in galvanized finish or painted
- Increased loading capability available. Contact Rilco for additional information
- Support constructed in accordance with ASME B31.1, B31.3 and MSS-SP58
- A307 or A193 B7 plated bolts/studs

For special applications or for information on other insulation thicknesses or pipe sizes, please contact us!

Ordering Instructions:

To Order, Please Specify:

- Model Number
- Nominal Pipe Size
- Insulation Thickness
- Vertical Load
- Movements

* See page 69 of this catalog for new designation model number construction.

** Information presented on this page subject to change without notice.

IG(180)DL - 8 x 3 - 6

LEGACY DESIGNATION IG-180-DL-R

Model No. Nominal Pipe Size (in) Insulation Thickness (in) BOP (in)

DESIGNATION EXAMPLE

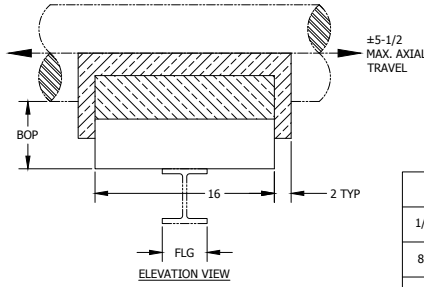
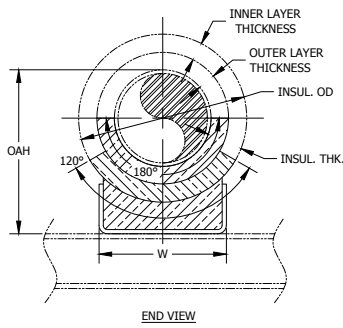

NPS	FLG (MIN)
1/2" - 6"	3"
8" - 24"	6"
26" - 72"	8"

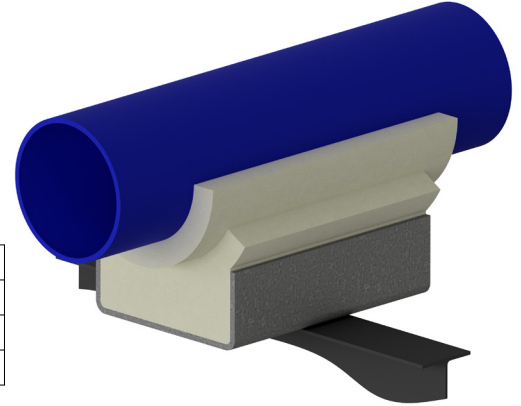

NOTES:

1) All dimensions in inches unless noted.

PIPE SIZE	INSULATION THICKNESS																			
	3-1/2"				4"				4-1/2"				5"				5-1/2"			
	BOP (in)	VERTICAL LOAD (lbs)	OAH (in)	W (in)	BOP (in)	VERTICAL LOAD (lbs)	OAH (in)	W (in)	BOP (in)	VERTICAL LOAD (lbs)	OAH (in)	W (in)	BOP (in)	VERTICAL LOAD (lbs)	OAH (in)	W (in)	BOP (in)	VERTICAL LOAD (lbs)	OAH (in)	W (in)
Do you need special loads or dimensions for this design? Please contact us at (713) 466-4777 or sales@rilco.com!																				
1/2"	6	715	6.875	5.5	6	797	6.875	6.25	6	879	6.875	7	8	961	8.875	7.625	8	1043	8.875	8.375
3/4"	6	716	7	5.75	6	798	7	6.375	6	880	7	7.125	8	962	9	7.875	8	1044	9	8.5
1"	6	717	7.375	5.875	6	799	7.375	6.625	6	881	7.375	7.25	8	963	9.375	8	8	1045	9.375	8.75
1-1/4"	6	736	7.625	6.125	6	797	7.625	6.875	6	868	7.625	7.5	8	930	9.625	8.25	8	1091	9.625	9
1-1/2"	6	797	7.875	6.25	6	890	7.875	7	6	961	7.875	7.75	8	1054	9.875	8.375	8	1125	9.875	9.125
2"	6	795	8.375	6.625	6	888	8.375	7.375	6	959	8.375	8	8	1052	10.375	8.75	8	1123	10.375	9.5
3"	6	920	9.5	7.375	6	1002	9.5	8.125	6	1076	9.5	8.875	8	1158	11.5	9.5	8	1240	11.5	10.25
4"	6	971	10.5	8.125	6	1053	10.5	8.875	6	1158	10.5	9.5	8	1240	12.5	10.25	8	1322	12.5	11
6"	6	1151	12.63	9.625	6	1233	12.63	10.375	6	1332	12.63	11	8	1414	14.625	11.75	8	1496	14.625	12.5
8"	6	1973	14.63	11	6	2096	14.63	11.75	8	2243	16.63	12.5	8	2366	16.625	13.125	8	2489	16.625	13.875
10"	6	3365	16.75	12.5	6	3552	16.75	13.25	8	3801	18.75	14	8	4028	18.75	14.625	8	4352	18.75	15.375
12"	6	5607	18.75	14	6	5925	18.75	14.625	8	6175	20.75	15.375	8	6361	20.75	16.125	8	6548	20.75	16.75
14"	6	5912	20	14.875	6	6192	20	15.5	8	6472	22	16.25	8	6501	22	17	8	6688	22	17.625
16"	6	6472	22	16.25	8	6752	24	17	8	7032	24	17.625	8	7312	24	18.375	8	7592	24	19.125
18"	6	11720	24	17.625	8	12187	26	18.375	8	12654	26	19.125	8	13120	26	19.75	8	13587	26	20.5
20"	6	12654	26	19.125	8	13120	28	19.75	8	13587	28	20.5	8	14054	28	21.25	8	14520	28	21.875
24"	6	19360	30	21.875	8	19983	32	22.625	8	20605	32	23.375	8	21227	32	24	8	21849	32	24.75
30"	8	37464	38	26.125	8	38595	38	26.875	8	39726	38	27.625	8	40858	38	28.25	10	41989	40	29
36"	8	39726	44	30.375	8	40858	44	31.125	8	41989	44	31.875	8	43121	44	32.5	10	44252	46	33.25
42"	8	41989	50	34.625	8	43121	50	35.375	8	44252	50	36	8	45383	50	36.75	10	46515	52	37.5
48"	8	44252	56	38.875	8	45383	56	39.625	8	46515	56	40.25	8	47646	56	41	10	48777	58	41.75
52"	8	46515	60	41.75	8	47646	60	42.375	8	48777	60	43.125	8	49909	60	43.875	10	51040	62	44.5
60"	8	48777	68	47.375	8	49909	68	48.125	8	51040	68	48.75	8	52172	68	49.5	10	53303	70	50.25

Applications & Features:

- Temperature range from -425 Deg F to 275 Deg F
- Higher temperature applications available
- Design loads based on a safety factor of 5
- A36 steel construction
- See technical specification RCS-750
- Test results available upon request
- Steel finish available in galvanized finish or painted
- Increased loading capability available. Contact Rilco for additional information
- Support constructed in accordance with ASME B31.1, B31.3 and MSS-SP58
- A307 or A193 B7 plated bolts/studs

For special applications or for information on other insulation thicknesses or pipe sizes, please contact us!

Ordering Instructions:

To Order, Please Specify:

- Model Number
- Nominal Pipe Size
- Insulation Thickness
- Vertical Load
- Movements

* See page 69 of this catalog for new designation model number construction.

** Information presented on this page subject to change without notice.

IG(180)DL - 8 x 3 - 6

DESIGNATION EXAMPLE

LEGACY DESIGNATION IG-180-DL-R

Model No. Nominal Pipe Size (in) Insulation Thickness (in) BOP (in)

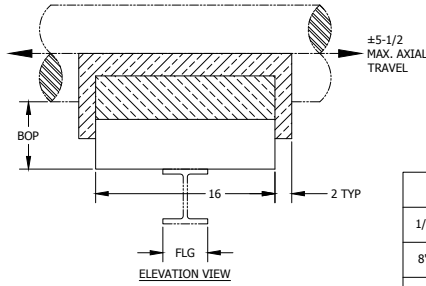
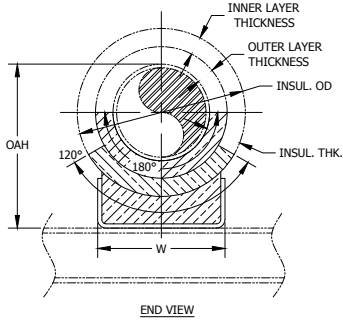

NPS	FLG (MIN)
1/2" - 6"	3"
8" - 24"	6"
26" - 72"	8"

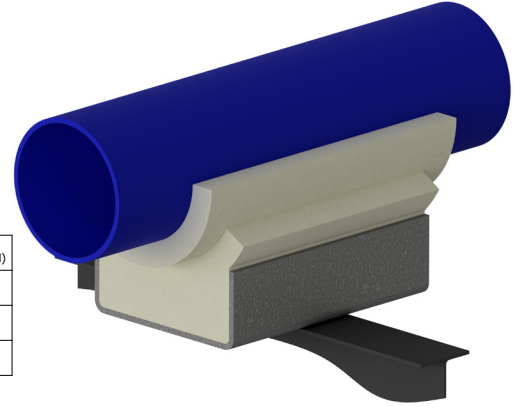

NOTES:

1) All dimensions in inches unless noted.

PIPE SIZE	INSULATION THICKNESS															
	6"				6-1/2"				7"				7-1/2"			
	BOP (in)	VERTICAL LOAD (lbs)	OAH (in)	W (in)	BOP (in)	VERTICAL LOAD (lbs)	OAH (in)	W (in)	BOP (in)	VERTICAL LOAD (lbs)	OAH (in)	W (in)	BOP (in)	VERTICAL LOAD (lbs)	OAH (in)	W (in)
Do you need special loads or dimensions for this design? Please contact us at (713) 466-4777 or sales@rilco.com!																
1/2"	8	1125	8.875	9.125	8	1207	8.875	9.75	10	1289	10.88	10.5	10	1371	10.875	11.25
3/4"	8	1126	9	9.25	8	1208	9	9.875	10	1290	11	10.625	10	1372	11	11.375
1"	8	1127	9.375	9.375	8	1209	9.375	10.125	10	1291	11.38	10.875	10	1373	11.375	11.5
1-1/4"	8	1168	9.625	9.625	8	1229	9.625	10.375	10	1291	11.63	11.125	10	1352	11.625	11.75
1-1/2"	8	1218	9.875	9.875	8	1289	9.875	10.5	10	1382	11.88	11.25	10	1453	11.875	12
2"	8	1216	10.38	10.125	8	1287	10.38	10.875	10	1380	12.38	11.625	10	1451	12.375	12.25
3"	8	1322	11.5	11	8	1404	11.5	11.625	10	1486	13.5	12.375	10	1568	13.5	13.125
4"	8	1404	12.5	11.625	8	1486	12.5	12.375	10	1568	14.5	13.125	10	1650	14.5	13.75
6"	8	1578	14.63	13.125	8	1660	14.63	13.875	10	1742	16.63	14.625	10	1824	16.625	15.25
8"	8	2612	16.63	14.625	10	2736	18.63	15.25	10	2859	18.63	16	10	2982	18.625	16.75
10"	8	4575	18.75	16.125	10	4796	20.75	16.75	10	4921	20.75	17.5	10	5044	20.75	18.25
12"	8	6735	20.75	17.5	10	6921	22.75	18.25	10	7108	22.75	18.875	10	7295	22.75	19.625
14"	8	6875	22	18.375	10	7061	24	19.125	10	7248	24	19.75	10	7435	24	20.5
16"	10	7872	26	19.75	10	8152	26	20.5	10	8432	26	21.25	10	8712	26	21.875
18"	10	14054	28	21.25	10	14520	28	21.875	10	14987	28	22.625	10	15454	28	23.375
20"	10	14987	30	22.625	10	15454	30	23.375	10	15920	30	24	10	16387	30	24.75
24"	10	22472	34	25.5	10	23094	34	26.125	10	23716	34	26.875	10	24339	34	27.625
30"	10	43121	40	29.75	10	44252	40	30.375	10	45383	40	31.125	12	46515	42	31.875
36"	10	45383	46	34	10	46515	46	34.625	10	47646	46	35.375	12	48777	48	36
42"	10	47646	52	38.125	10	48777	52	38.875	10	49909	52	39.625	12	51040	54	40.25
48"	10	49909	58	42.375	10	51040	58	43.125	10	52172	58	43.875	12	53303	60	44.5
52"	10	52172	62	45.25	10	53303	62	46	10	54432	62	46.625	12	55566	64	47.375
60"	10	54432	70	50.875	10	55566	70	51.625	10	56697	70	52.375	12	57828	72	53

Applications & Features:

- Temperature range from -425 Deg F to 275 Deg F
- Higher temperature applications available
- Design loads based on a safety factor of 5
- A36 steel construction
- See technical specification RCS-750
- Test results available upon request
- Steel finish available in galvanized finish or painted
- Increased loading capability available. Contact Rilco for additional information
- Support constructed in accordance with ASME B31.1, B31.3 and MSS-SP58
- A307 or A193 B7 plated bolts/studs

For special applications or for information on other insulation thicknesses or pipe sizes, please contact us!

Ordering Instructions:

To Order, Please Specify:

- Model Number
- Nominal Pipe Size
- Insulation Thickness
- Vertical Load
- Movements

* See page 69 of this catalog for new designation model number construction.

** Information presented on this page subject to change without notice.